



Operating the THERMOMARK GO thermal transfer printer

User manual

User manual

Operating the THERMOMARK GO thermal transfer printer

UM EN THERMOMARK GO, Revision 01

2022-07-28

This user manual is valid for:

Designation	Version	Order No.
THERMOMARK GO		1090747
THERMOMARK GO SET		1221548

109381_en_01

Table of contents

1	For your safety	5
1.1	Identification of warning notes.....	5
1.2	Qualification of users	5
1.3	Field of application.....	6
1.4	Safety notes	6
2	Starting up the printer	7
2.1	Checking the scope of supply	7
2.2	Overview of the device.....	8
2.3	Connecting the power supply.....	9
2.4	Inserting the material cartridge.....	11
2.5	Switching on the device	12
2.6	Operation.....	13
2.7	Printing and cutting	14
3	Maintenance and troubleshooting	15
3.1	Cleaning.....	15
3.2	Troubleshooting.....	17
3.3	Repairs	21
3.4	Firmware update.....	21
3.5	Disposal.....	21
4	Appendix	22
4.1	Technical data	22
4.2	Ordering data for accessories.....	23
4.3	Approvals.....	24

1 For your safety

Read this user manual carefully and keep it for future reference.

1.1 Identification of warning notes



This symbol indicates hazards that could lead to personal injury.

There are three signal words indicating the severity of a potential injury.

DANGER

Indicates a hazard with a high risk level. If this hazardous situation is not avoided, it will result in death or serious injury.

WARNING

Indicates a hazard with a medium risk level. If this hazardous situation is not avoided, it could result in death or serious injury.

CAUTION

Indicates a hazard with a low risk level. If this hazardous situation is not avoided, it could result in minor or moderate injury.



This symbol together with the **NOTE** signal word warns the reader of actions that might cause property damage or a malfunction.



Here you will find additional information or detailed sources of information.

1.2 Qualification of users

This user manual is aimed at those persons who are familiar with the relevant safety concepts for handling electrical equipment.

1.3 Field of application

The THERMOMARK GO is a portable thermal transfer printer for industrial and private use. The thermal transfer printer prints pre-punched die-cut labels and materials in continuous format for the following applications:

- Equipment marking
- Cable marking
- Terminal marking

The THERMOMARK GO uses special material cartridges that contain the material as well as the corresponding ink ribbon. Only use material cartridges that are provided for the THERMOMARK GO by Phoenix Contact.

1.4 Safety notes

Hazard to operational safety

Incorrect operation or modifications to the device can endanger your safety or damage the printer. Do not repair the device yourself. If the device is defective, please contact Phoenix Contact.

This device is not suitable for use at locations where children might be present.

Explosion hazard, fire hazard, and health hazard if batteries are used incorrectly

- Only use dry batteries in a proper condition. Only the supplied battery is suitable for battery operation (THERMOMARK GO ACCU, 0805009).
- Never damage the batteries (e.g., by throwing, pressing on the battery or using sharp objects). Never expose the batteries to high levels of heat (e.g., caused by fire or sunlight). Never let the batteries come in contact with moisture or salt water.
- Pay attention to the correct polarity when inserting the batteries.
- Only charge the battery in the THERMOMARK GO or in the provided charger (THERMOMARK GO CHARGER, 0805012). Do not use any other chargers, e.g., cigarette lighter socket in the car.
- Temperature range when charging the battery: 0°C ... 45°C
- Store the battery separately in a dry and cool place.
- Never expose batteries to an extremely low air pressure.

Damage to the device

- Do not operate the printer near high-voltage lines.
- Only operate the printer in a dry location protected from splash water.
- Protect the printer and printing materials from humidity, moisture, and dirt.
- Only connect the printer to systems that have a protective extra low voltage.
- To operate the printer on the power grid, only use the supplied wide range power supply unit (THERMOMARK GO ADAPTER, 0805010).

2 Starting up the printer

2.1 Checking the scope of supply

THERMOMARK GO

- Printer
- Brief instructions
- Rechargeable battery (THERMOMARK GO ACCU, 0805009)
- Wide range power supply unit with power cable and four adapters for different sockets (THERMOMARK GO ADAPTER, 0805010)
- USB cable
- Material cartridge (MM-EML (20X8)R C1 WH/BK, 1116204)

Unpacking

- Check the printer for transport damage.
- Remove the protective foil from the display and from the window of the compartment for the material cartridge.

2.2 Overview of the device

Figure 2-1 Overview

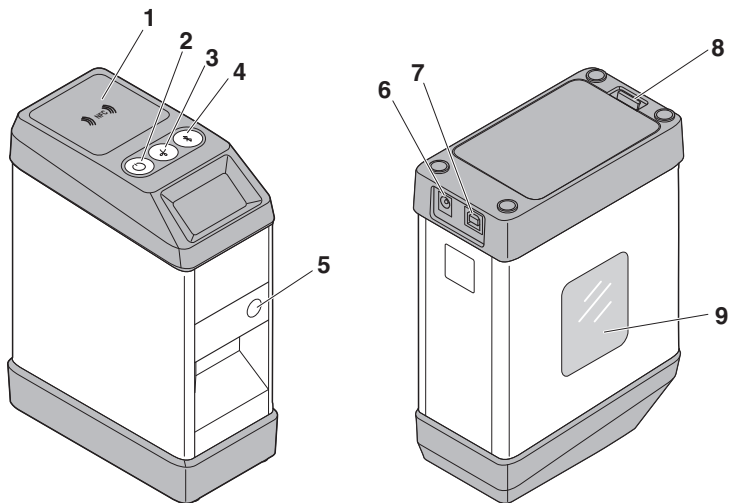

- | | | | |
|----------|---------------------------|----------|------------------------------------|
| 1 | NFC area | 6 | Socket for power supply unit |
| 2 | On/Off switch | 7 | Socket for USB connection |
| 3 | Cutter | 8 | Battery compartment |
| 4 | Bluetooth reset | 9 | Compartment for material cartridge |
| 5 | Open material compartment | | |

2.3 Connecting the power supply

The THERMOMARK GO can be supplied with power in different ways.

- Batteries (6x AA alkaline)
- AC wide range power supply unit (THERMOMARK GO ADAPTER, 0805010)
- Battery (THERMOMARK GO ACCU, 0805009)

If the THERMOMARK GO is connected to the power supply via the power supply unit, the battery in the THERMOMARK GO is automatically charged. The battery can also be charged using an external charger (THERMOMARK GO CHARGER, 0805012).

Connecting the power supply unit

The wide range power supply unit is designed for power grids from 100 to 240 V AC.

Only use the supplied wide range power supply unit (THERMOMARK GO ADAPTER, 0805010).

Figure 2-2 Mains connection

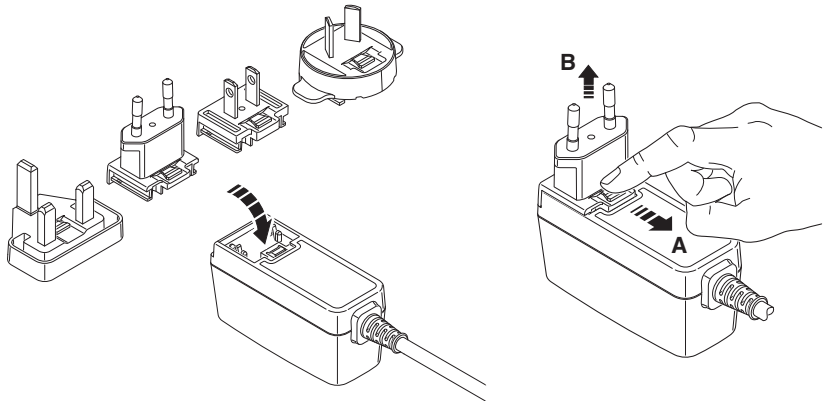

- Slightly tilt the relevant adapter and place it onto the front side of the power supply unit and press the adapter down. To remove the adapter, pull the slider on the base element in the direction of the cable.
- Plug the connecting cable of the power supply unit into the socket on the printer.
- Plug the power supply unit into the socket.

Inserting the battery

Figure 2-3 Opening the battery compartment

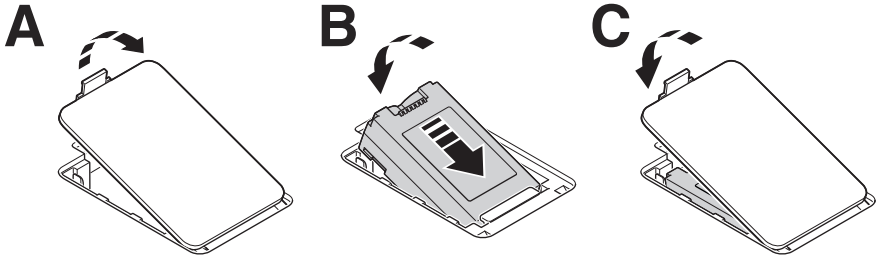

WARNING: Explosion hazard

Only use batteries of the stated type. Using incorrect types may disable protective measures.



WARNING: Risk of fire

Only operate the device if the battery cover is closed correctly. Combustible material close to the battery compartment may ignite.

- To open the battery compartment, push the interlock of the cover in the direction of the connections.
- Slightly tilting the battery, insert it into the battery compartment making sure of the correct polarity.
- Press down the battery.
- Close the cover.

2.4 Inserting the material cartridge

Before inserting the material cartridge: Make sure that approx. 5 mm of material is protruding from the material cartridge. If this is not the case, unwind the material a little.

Figure 2-4 Unwinding the material

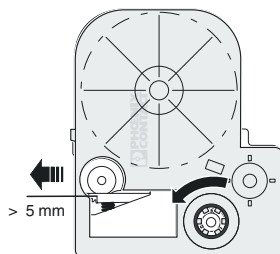

- Unwind the material approx. 5 mm from the material cartridge.
- To increase the tension of the material, turn the ink ribbon reel.

Figure 2-5 Replacing the material cartridge

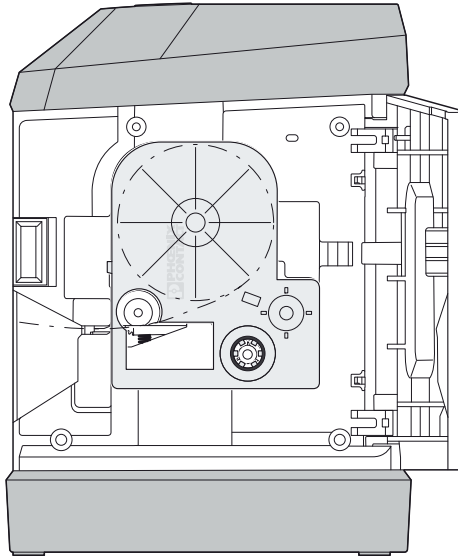

- To open the material compartment, push the green button.
- Keeping the material cartridge straight, insert it into the compartment from the side so that it engages with a click.
Make sure that the material end is in the output tray.
- To remove the material cartridge, pull it sideways while keeping it straight.



NOTE: Damage to the printer and material cartridge

If the printer is not going to be used for a prolonged period of time, remove the material cartridge from the printer.

2.5 Switching on the device

- Press the gray  button to switch on the printer. The display lights up.

2.6 Operation

You have the following options for operating your printer:

- You can operate the printer via Bluetooth using the mobile “MARKING system” app.
- You can operate the printer via the USB interface using the PROJECT complete PC software.

Operation via smartphone (MARKING system app)

Figure 2-6 MARKING system app



- Install the “MARKING system” app via the Apple App Store or the Google Play Store. Use the QR code to go directly to the relevant store.
- Open the app. When you place your mobile Android end device with NFC interface on the NFC area of the printer, the app opens automatically. To do this, the mobile end device must support NFC.
- Enable Bluetooth on your mobile end device.
- The connected printers and their ID are shown in the app. The ID can be seen on the printer display (e.g., TMGO_0000).

Operation via PC (PROJECT complete marking)

- Download the PROJECT complete marking software. The software can be found at: phoenixcontact.net/qr/1050453
- Install the PROJECT complete marking software on your PC.
- Connect the printer to the PC via USB.
- Switch on the printer.
- Start the PROJECT complete marking software.
- In the printer configuration, select the device with the ID of the printer. The ID can be seen on the printer display (e.g., TMGO_0000).

2.7 Printing and cutting

Printing

- If you want to print marking material, create a print job via the “PROJECT complete” software or “MARKING system” app.
 - Send the print job to the printer via the USB interface or Bluetooth.
- ⇒ The loaded marking material is printed accordingly.

Cutting

- If printing multiple labels, you can choose to cut the labels right away or later. If you want to cut the labels later, the printer can add a line at the cutting position. The device performs cutting automatically when the cut setting is selected. After the cut, the device continues printing.
- Press the “Cutter” button (see 3 in [Figure 2-1](#)) to cut the material. In the case of continuous media, the material is cut after a low feed rate. In the case of die-cut materials, the material is fed as far as the next label and cut.

3 Maintenance and troubleshooting

3.1 Cleaning

3.1.1 Cleaning the printer



NOTE: Damage to the printer due to abrasive cleaning agents

Do not use abrasive cleaners or aggressive solvents to clean the outer surfaces.

- Remove dust and paper fluff in the printing area with a soft brush.
- Clean the outer surfaces with a damp cloth. Use an all-purpose cleaner for higher levels of contamination.

3.1.2 Cleaning the print head and pressure roller

During printing, substances may be deposited on the print head or pressure roller. It is important to clean the print head and pressure roller regularly. This ensures consistent printing quality and extends the service life of the printer.



NOTE: Damage to the print head

Do not touch the protective glass of the print head with your fingers or sharp objects. Do not use sharp or hard objects to clean the print head.

Figure 3-1 Print head (1) and pressure roller (2)

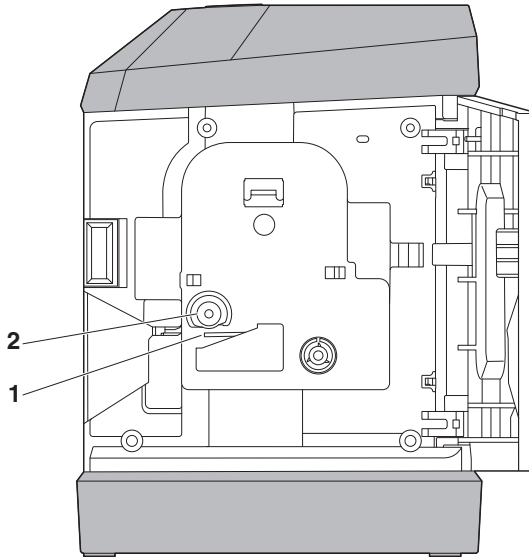

- Open the compartment for the material cartridge and remove the material cartridge.
- Clean the print head line and pressure roller with a felt stick (e.g., CLEANING STICK, 5146697) soaked in isopropyl alcohol.
- Allow the print head to dry for two to three minutes.

3.2 Troubleshooting

3.2.1 Reset

Device reset

In the event of a general system error, you can restart the printer by performing a reset.

- To perform a reset, simultaneously press the three buttons on the device (buttons 2, 3, and 4 in [Figure 2-1](#)).
- ⇒ The printer is reset to the factory settings.

Resetting the Bluetooth connection

In the event of a connection error, you can perform a reset to reset the Bluetooth connection.

- To perform a Bluetooth reset, press the Bluetooth reset button (button 4 in [Figure 2-1](#)).

3.2.2 Troubleshooting

Table 3-1 Troubleshooting

Problem	Possible cause	Remedy
Print image is blurred or missing in places	Print head or pressure roller is dirty	Clean the print head and pressure roller (see 3.1.2)
	The tension of the ink ribbon is too low	To increase the tension of the material, turn the ink ribbon reel

Table 3-1 Troubleshooting

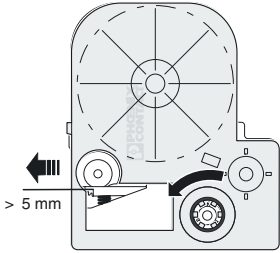
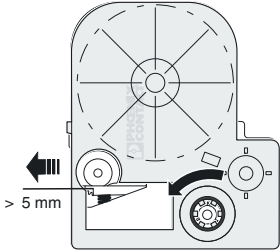
Problem	Possible cause	Remedy
Material is not being supplied	Not enough material has been unwound from the material cartridge	<p>Unwind the material approx. 5 mm from the material cartridge. To increase the tension of the material, turn the ink ribbon reel</p> 
	Material is stuck in the printer	<p>Carefully remove the material from the printer. Cut off damaged material. Unwind the material approx. 5 mm from the material cartridge. To increase the tension of the material, turn the ink ribbon reel</p> 
	Material cartridge is empty	Insert a new material cartridge (see 2.4)
	Compartment for material cartridge is open	Close compartment

Starting up the printer

Table 3-1 Troubleshooting

Problem	Possible cause	Remedy
Material is being supplied but not printed	Ink ribbon is torn	Insert a new material cartridge (see 2.4)
Printer is loud	Material cartridge is not inserted correctly	
	Material cartridge is defective	
Printer prints slowly	Compartment for material cartridge is open	Close compartment
	Printing speed is automatically adjusted	When the battery state of charge is below a certain level, the printing speed is reduced. This ensures consistently high printing quality.
The printer cannot be switched on	Batteries are dead	Change batteries
	Batteries are inserted incorrectly	Insert batteries correctly
	Rechargeable battery is dead	Recharge battery
	Rechargeable battery is inserted incorrectly	Insert rechargeable battery correctly
	No power supply	Connecting the power supply unit
Battery is not charged	Battery is inserted incorrectly	Insert battery correctly
	No power supply	Connecting the power supply unit
	Rechargeable battery is defective	Dispose of battery properly. Insert new battery
Printer is not responding	General system error	Switch device off and on again. Disconnect the device from the power supply. Remove batteries. Insert new ones. Perform a reset (see “Reset” on page 17)

3.2.3 Status and error messages

Table 3-2 Status messages

Status message	Meaning
“Printing...”	Print job is being printed and the marked material is being output
“Ready”	The printer is ready to process a print job
“Cancel print”	Printer cancels the print job
“Low battery”	The rechargeable battery or the batteries are almost dead and need to be recharged or replaced soon
“Cutting...”	Marking material is being cut by the automatic cutting unit
“Cover open”	Compartment for material cartridge is open
“Feeding...”	Marking material is being fed toward the print head
“BT Reset”	Bluetooth signal will be re-established

Table 3-3 Error messages

Error message	Possible cause	Remedy
“Cutter error”	Marking material has got stuck in the cutter and is preventing cutting	Remove the marking material from the cutter. Switch device off and on again Perform a reset (see “Reset” on page 17)
“No cartridge”	No material cartridge inserted	Insert material cartridge
“Cartridge empty”	Material cartridge is empty	Insert new material cartridge

3.3 Repairs



WARNING: Hazard to operational safety

Incorrect operation or modifications to the device can endanger your safety or damage the printer. Do not repair the device yourself. If the device is defective, please contact Phoenix Contact.

3.4 Firmware update

To benefit from improvements and function extensions, you can download a firmware update. Firmware updates are made available at:

phoenixcontact.net/qr/1090747

3.5 Disposal



The symbol with the crossed-out trash can indicates that this item must be collected and disposed of separately. Phoenix Contact or our service partners will take the item back for free disposal. For information on the available disposal options, visit phoenixcontact.com. Collect and dispose of included batteries separately from other waste. Delete personal data before returning the item.



Dispose of the material cartridge separately from other waste, i.e., via an appropriate collection site.



Dispose of the battery separately from other waste, i.e., via an appropriate collection site.

4 Appendix

4.1 Technical data

Technical data	
Print mode	Thermal transfer
Resolution	203 dpi
Print speed	15 mm/s
Print length, minimum	7 mm
Print width, maximum	22 mm
Label width, maximum	24 mm
Interfaces	USB, Bluetooth, NFC
Display and operation	0.96" OLED display
Voltage	
Wide range power supply unit	100 V AC ... 240 V AC, 50/60 Hz
Printer	12 V DC, 3 A
Power, maximum	36 W
Frequency	2.402 GHz ... 2.480 GHz
Transmission power, maximum	+4 dBm (2.5 mW)
Temperature	
Operation	+5°C ... +40°C
Storage	-18°C ... +60°C
Transport	-25°C ... +60°C
Humidity	
Operation	10% ... 90%
Storage	5% ... 80%
Transport	5% ... 95%
Dimensions (H x D x W)	175 mm x 135 mm x 70 mm
Weight	750 g

4.2 Ordering data for accessories

Accessories

Description	Type	Item No.	Pcs. /Pkt.
Battery , to supply the THERMOMARK GO with power	THERMOMARK GO ACCU	0805009	1
Charger , for charging the THERMOMARK GO ACCU	THERMOMARK GO CHARGER	0805012	1
Wide range power supply unit , with four socket adapters	THERMOMARK GO ADAPTER	0805010	1
Transport bag , flexible shoulder bag and belt pouch	THERMOMARK GO BAG	1229457	1
Case in L-BOXX system, for storing the THERMOMARK GO and THERMOMARK GO.K mobile printers as well as the necessary accessories	THERMOMARK GO CASE	1229456	1
Cleaning stick , for cleaning the print head line and the pressure roller	CLEANING STICK	5146697	1

4.3 Approvals

4.3.1 FCC

FCC Supplier's Declaration of Conformity

PHOENIX CONTACT / THERMOMARK GO

This device complies with part 15 of the FCC Rules. Operation is subject to the following two conditions: (1) This device may not cause harmful interference, and (2) this device must accept any interference received, including interference that may cause undesired operation.

PHOENIX CONTACT | 586 Fulling Mill Road
Middletown, PA 17057 | (800) 888-7388

Caution: The user is cautioned that changes or modifications not expressly approved by the party responsible for compliance could void the user's authority to operate the equipment. Note: This equipment has been tested and found to comply with the limits for a Class B digital device, pursuant to part 15 of the FCC Rules. These limits are designed to provide reasonable protection against harmful interference in a residential installation. This equipment generates uses and can radiate radio frequency energy and, if not installed and used in accordance with the instructions, may cause harmful interference to radio communications. However, there is no guarantee that interference will not occur in a particular installation. If this equipment does cause harmful interference to radio or television reception, which can be determined by turning the equipment off and on, the user is encouraged to try to correct the interference by one or more of the following measures:

- Reorient or relocate the receiving antenna.
- Increase the separation between the equipment and receiver.
- Connect the equipment into an outlet on a circuit different from that to which the receiver is connected.
- Consult the dealer or an experienced radio/TV technician for help.

FCC RF Radiation Exposure Statement

This equipment complies with FCC radiation exposure limits set forth for an uncontrolled environment. This equipment should be installed and operated with a minimum distance of 20 cm between the radiator and any part of your body.

IC

This device contains licence-exempt transmitter(s)/receiver(s) that comply with Innovation, Science and Economic Development Canada's licence-exempt RSS(s). Operation is subject to the following two conditions:

1. This device may not cause interference.
2. This device must accept any interference, including interference that may cause undesired operation of the device.

L'émetteur/récepteur exempt de licence contenu dans le présent appareil est conforme aux CNR d'Innovation, Sciences et Développement économique Canada applicables aux appareils radio exempts de licence. L'exploitation est autorisée aux deux conditions suivantes :

1. L'appareil ne doit pas produire de brouillage;
2. L'appareil doit accepter tout brouillage radioélectrique subi, même si le brouillage est susceptible d'en compromettre le fonctionnement.

This equipment complies with ISED RSS-102 radiation exposure limits set forth for an uncontrolled environment. This equipment should be installed and operated with a minimum distance of 20 cm between the radiator and any part of your body.

Pour se conformer aux exigences de conformité CNR 102 RF exposition, une distance de séparation d'au moins 20 cm doit être maintenue entre l'antenne de cet appareil et toutes les personnes.

4.3.2 UL



WARNING: Hazardous moving parts

Keep fingers and other body parts away.

Please observe the following notes

General Terms and Conditions of use for technical documentation

Phoenix Contact reserves the right to alter, correct, and/or improve the technical documentation and the products described in the technical documentation at its own discretion and without giving prior notice, insofar as this is reasonable for the user. The same applies to any technical changes that serve the purpose of technical progress.

The receipt of technical documentation (in particular user documentation) does not constitute any further duty on the part of Phoenix Contact to furnish information on modifications to products and/or technical documentation. You are responsible to verify the suitability and intended use of the products in your specific application, in particular with regard to observing the applicable standards and regulations. All information made available in the technical data is supplied without any accompanying guarantee, whether expressly mentioned, implied or tacitly assumed.

In general, the provisions of the current general Terms and Conditions of Phoenix Contact apply exclusively, in particular as concerns any warranty liability.

This manual, including all illustrations contained herein, is copyright protected. Any changes to the contents or the publication of extracts of this document are prohibited.

Phoenix Contact reserves the right to register its own intellectual property rights for the product identifications of Phoenix Contact products that are used here. Registration of such intellectual property rights by third parties is prohibited.

Other product identifications may be afforded legal protection, even where they may not be indicated as such.

How to contact us

Internet

Up-to-date information on Phoenix Contact products and our Terms and Conditions can be found on the Internet at:

phoenixcontact.com

Make sure you always use the latest documentation.

It can be downloaded at:

phoenixcontact.net/products

Subsidiaries

If there are any problems that cannot be solved using the documentation, please contact your Phoenix Contact subsidiary.

Subsidiary contact information is available at phoenixcontact.com.

Published by

PHOENIX CONTACT GmbH & Co. KG

Flachsmarktstraße 8

32825 Blomberg

GERMANY

Should you have any suggestions or recommendations for improvement of the contents and layout of our manuals, please send your comments to:

tecdoc@phoenixcontact.com

PHOENIX CONTACT GmbH & Co. KG
Flachmarktstraße 8
32825 Blomberg, Germany
Phone: +49 5235 3-00
Fax: +49 5235 3-41200
E-mail: info@phoenixcontact.com
phoenixcontact.com

© PHOENIX CONTACT

109381_en_01
Order No. —01



INSPIRING INNOVATIONS